Electric Pallet truck

15/18/20EP



■ Photo may include optional equipment.

Standard Configurations

15EP

- Lifting Capacity : 1500 kg
- Brushless Drive Motor 0.9 kW
- Lifting Motor : 0.8 kW
- Drive Wheel : 195 x 70mm
- Double Polyurethane Load wheels wheel (size: 80 x 70 mm)
- Hourmeter, Battery Discharge Indicator (BDI) & lift cut off
- Overall Fork Width x Length : 550 mm x 1150 mm
- Turtle switch / crawl speed button
- Belly switch
- Gel battery
- Integrated charger
- Emergency switch
- Ergonomic tiller

18EP

- Lifting Capacity : 1800 kg
- AC Drive Motor 1.2 kW
- Lift motor 1.2 kW
- Curtis controller
- Drive wheel : 250 x 70mm
- Double Polyurethane Load wheel wheel (size: 80 x 70 mm)
- Hourmeter, Battery Discharge Indicator (BDI) & lift cut off
- Overall Fork Width x Length : 550 mm x 1150 mm
- Turtle switch / crawl speed button
- Ergonomic low-mounted tiller
- Side Battery Removal
- Emergency switch
- Belly switch

20EP

- Lifting Capacity : 2000 kg
- AC Drive Motor 1.2 kW
- Lift motor 1.2 kW
- Curtis controller
- Drive wheel : 250 x 70mm
- Double Polyurethane Load wheel wheel (size: 82 x 98 mm)
- Hourmeter, Battery Discharge Indicator (BDI) & lift cut off
- Overall Fork Width x Length : 550 mm x 1150 mm
- Turtle switch / crawl speed button
- Ergonomic low-mounted tiller
- Side Battery Removal
- Emergency switch
- Belly switch

Advantages

SAFETY AND PRODUCTIVITY

- AC technology gives high performance and low maintenance (no carbon brushes)
- Intelligent regenerative brake system for fast and efficient handling
- Side battery removal, for multiple shift operation
- Turtle mode switch, for safe maneuverability with tiller in upright position
- Proportional speed control ensures precise operation
- Anti roll-back on gradients (parking brake)

STRUCTURE DESIGN

- The motor structure is resistant to dust and moisture
- Improved lateral stability thanks to spring applied castor wheels
- Torsion resistant forks, welded type

SERVICEABILITY

- Increased serviceability by CANbus technology
- Grease fittings on all pivot points increase durability
- Easy access to all components thanks to removal of only 1-piece front cover

Electric Pallet truck

Dimensions

15EP

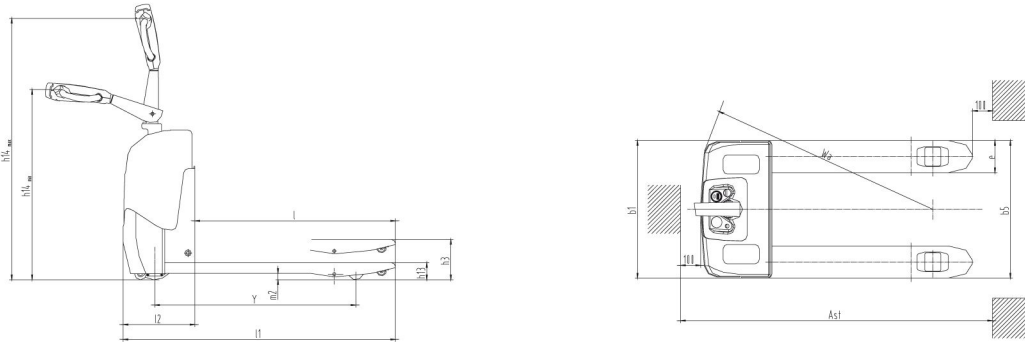

18/20EP

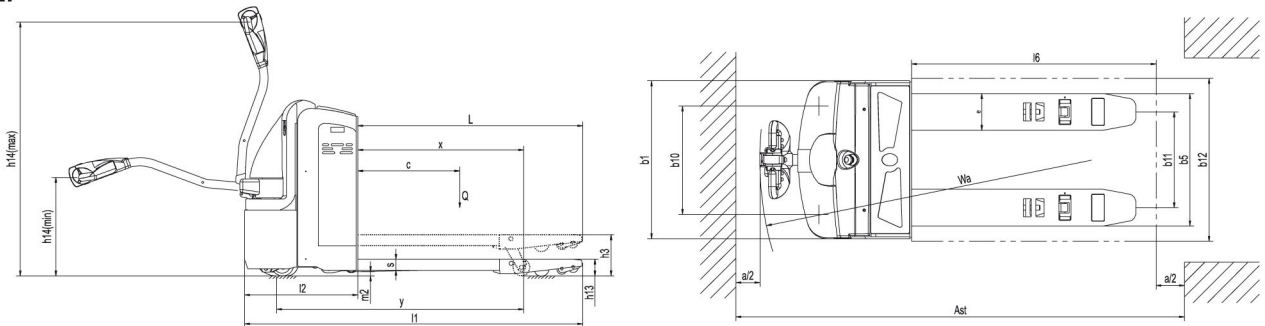

Option

15EP

- Loadguard 1220 mm
- Fork length (mm): 900; 1000; 1220
- Single PU Load Wheels (fork wheel size 80 x 70 mm)

18EP

- Integrated Charger (24V / 15A)
- Battery trolley
- Foot protection strip
- Keyless ignition (keypad)
- Loadguard 1220 mm
- Fork length (mm): 800; 900; 1000; 1220; 1600; 1800; 2400 mm
(1800; 2400 : rated load capacity 1.5t)

20EP

- Single PU load wheels (size 82 x 98)
- Integrated Charger (24V / 15A)
- Battery trolley
- Foot protection strip
- Keyless ignition (keypad)
- Loadguard 1220 mm
- Fork length (mm): 800; 900; 1000; 1220; 1600; 1800; 2400 mm
(1800; 2400 : rated load capacity 1.5t)

Specification (according to VDI 2198)

Characteristics						
1.1	manufacturer (abbreviation)			Hyundai	Hyundai	Hyundai
1.2	Model			15EP	18EP	20EP
1.3	Drive type			electric	electric	electric
1.4	Operator type			pedestrian	pedestrian	pedestrian
1.5	Load capacity/rated load	Q	kg	1500	1800	2000
1.6	Load center distance	c	mm	600	600	600
1.8	Load distance	x	mm	886 / 956	856	815 / 865 / 935
1.9	Wheelbase	y	mm	1152 / 1222	1200	1211 / 1261 / 1331
Weight						
2.1	Service weight(with battery)		kg	230	520	620
2.2	Axle load, front/rear, loaded		kg	442 / 1288	720 / 1600	1170 / 1450
2.3	Axle load, front/rear, unloaded		kg	200 / 30	420 / 100	470 / 150
Wheels/Chassis						
3.1	Tyres: solid rubber, superelastic, pneumatic, polyurethane			polyurethane	polyurethane	polyurethane
3.2	Tyre size, front			Φ 195 x 70	Φ 250 x 70	Φ 250 x 70
3.3	Tyre size, rear			Φ 80 / Φ 70	Φ 80 x 70	Φ 82 x 126
3.4	Additional wheels(dimensions)			Φ 60 x 35	Φ 114 x 60	Φ 127 x 57
3.5	Wheels number, front/rear (x = driven wheels)			1x -2/4	1x +2/4	1x +2/2
3.6	Tread, front	b10	mm	195	476	510
3.7	Tread, rear	b11	mm	80 / 74	400	340 / 370 / 470 / 505
Dimension						
4.4	Lift height	h5	mm	105 / 115	120	120
4.9	Min. /Max. height of operation handle, in driving position	h14	mm	950 / 1310	780 / 1230	780 / 1230
4.15	Height, lowered	h13	mm	85 / 75	84	82
4.19	Overall length	l1	mm	1525 / 1595	1651	1655 / 1705 / 1775
4.20	Length to fork face	l2	mm	373	500	555
4.21	Overall width of truck body	b1	mm	685	682	775
4.22	Fork dimension	s/e/l	mm	53 x 160 x 1150	54 x 150 x 1150	54 x 180 x 1150
4.25	Overall width of fork	b5	mm	520 / 550 / 685	550	520 / 550 / 650 / 685
4.32	Wheelbase ground distance	m2	mm	32 / 22	28	28
4.33	Aisle width, with pallet 1000 x 1200 crosswise	Ast	mm	1725 / 1795	1863	2015 / 2065 / 2135
4.34	Aisle width, with pallet 800 x 1200 lengthwise	Ast	mm	1775 / 1795	1913	2115 / 2115 / 2135
4.35	Turning radius	Wa	mm	1347 / 1415	1367	1400 / 1450 / 1520
Performance Data						
5.1	traveling speed, loaded/unloaded		km/h	5.3 / 5.8	6 / 6	5.5 / 5.6
5.2	Lifting speed, loaded/unloaded		m/s	0.035 / 0.045	0.06 / 0.11	0.039 / 0.056
5.3	Lowering speed, loaded/unloaded		m/s	0.08 / 0.037	0.12 / 0.13	0.064 / 0.050
5.7	Gradeability, loaded/unloaded		%	5 / 15	8 / 20	6 / 12
5.10	traveling brake			electromagnetic brake	electromagnetic brake	electromagnetic brake
Motor						
6.1	Driving motor power		kW	0.9	1.2	1.2
6.2	Lifting motor power		kW	0.8	1.2	1.2
6.4	Battery voltage/rated capacity		V/Ah	24 / 80	24 / 160	24 / 210
6.5	Battery weight		kg	49	160	170